

All technical data presented represent typical results, unless stated otherwise as min/max values. No guarantee is made that material will meet exactly the values shown.

6-Can Electrolyte Filler, VD102N-6A

6-Road Electrolyte Filling Machine

Model: VD 102N-6A

This machine is to fill electrolyte into 6 cylindrical cells.

1. Electrolyte is dispensed to sub tanks precisely by the HF plunger pump.
2. Cell sensor detects a cell in every cell holder to cancel e-filling for empty cell holders.

Power:	AC200V, 50/60Hz, 500W
Control:	PLC
Pressure:	0.5MPa (N2, Ar) required
Vacuum:	50L/min required
Filling Volume:	—20cc
Max. Vacuum:	-100kPa
Max. Pressure:	196kPa
Cell Holder:	18650 (26650, 26700, etc)

Flow Chart:

Cell Set

Cell Elevation

Plunger Pump Dispense

Vacuum: Max. -100kPa)

Vacuum Hold: Max. 99sec

Electrolyte Filling Start

Electrolyte Filing Stop

Vacuum Hold: Max. 99sec

Pressure Release

Pressurize: Max. 196kPa

Pressurize Hold: Max. 99sec

Pressure Release

Cell Release

Cell Pick-up

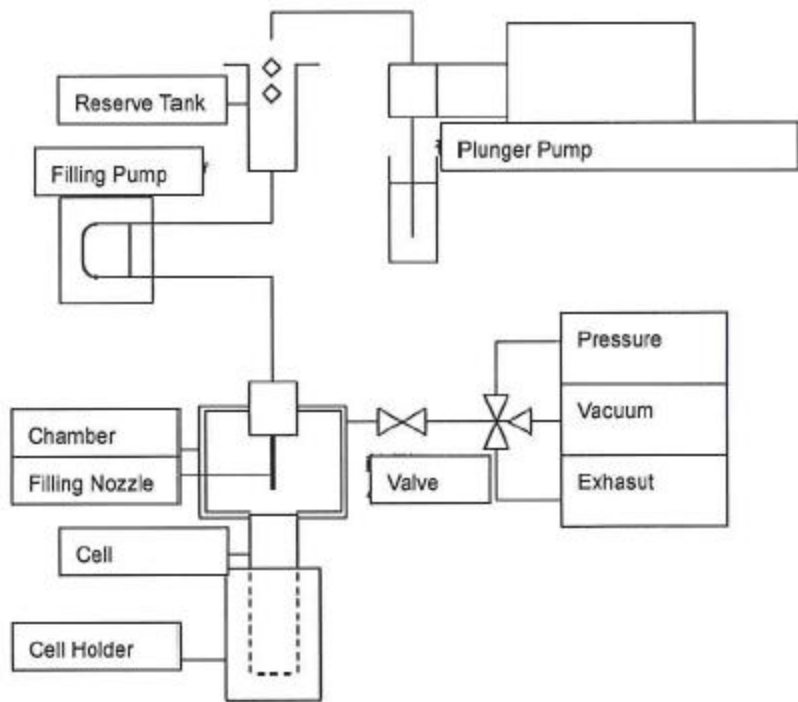

Application: Advanced energy

Product type: Machinery

Production scale: Lab

Search tags: Hohsen, Machinery, Electrolyte filler, Filling